

## Special Drive Unit for shower screen doors

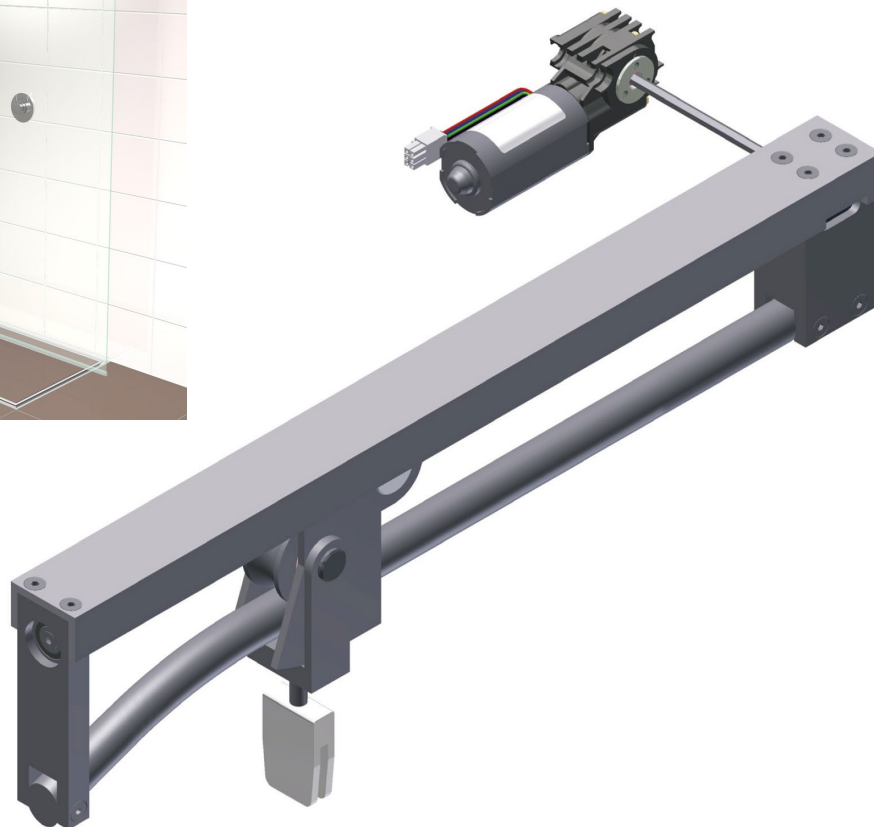

Customized Solution

108452

89 mm



### Special drive unit offers optimum functionality for shower screen doors

As well as design and functionality, issues concerning available space play an increasingly important role in modern bathrooms. Particularly in small bathrooms, the additional space won through the deployment of sliding shower screen doors, can offer many advantages.

Ketterer has developed a special transmission unit for just this application. Two space-saving, maintenance-free motorised transmissions are integrated in a guide track. This allows the position of the glass screen to be adjusted simply and quietly. The guide track is bent slightly forwards.

This guarantees that the glass screen forms a secure closure with the floor when the screen is in its end position. If the shower screen meets any resistance as it is travelling to the required position, an integrated safety mechanism ensures that there is no danger of injury and that the glass screen is not damaged.

Ketterer drive units fulfil their task reliably and efficiently even in such a demanding application as this. See for yourself and contact us for more information.