

t-Rex 3200 (long version, focus torque)

I-44-89-L41 S2



Description

14-pole BLDC motor with high-performance neodymium magnets and three digital Hall sensors to detect the rotor position. The electrical connections are designed as a plug-in system. Additional power electronics are required to operate the motor. The design of the motor with a hollow shaft allows the cables to run through the motor or output on both sides.

Special features

- Designed with **focus on max. torque**
- Enormous performance density – 3 times stronger than motors of comparable size
- High overload resistance
- Ideally suited as direct drive, or generator for gearless applications
- Special winding upon request
- Design and manufacture of motor to specified operating point is possible

3200.00-0005 with hollow shaft

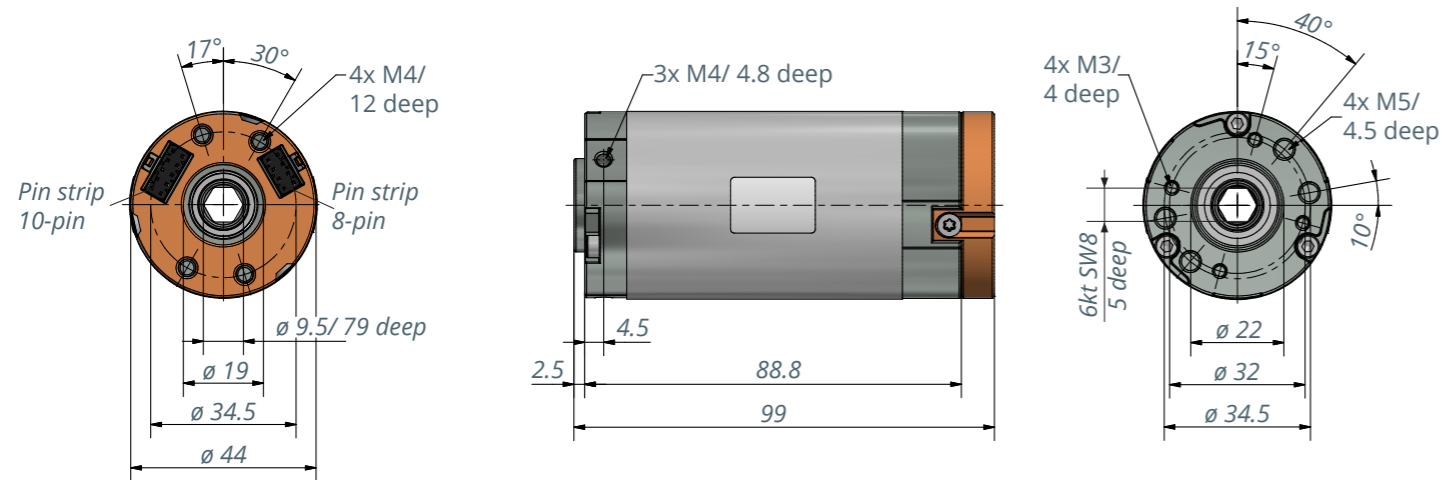

3200.00-0006 with shaft

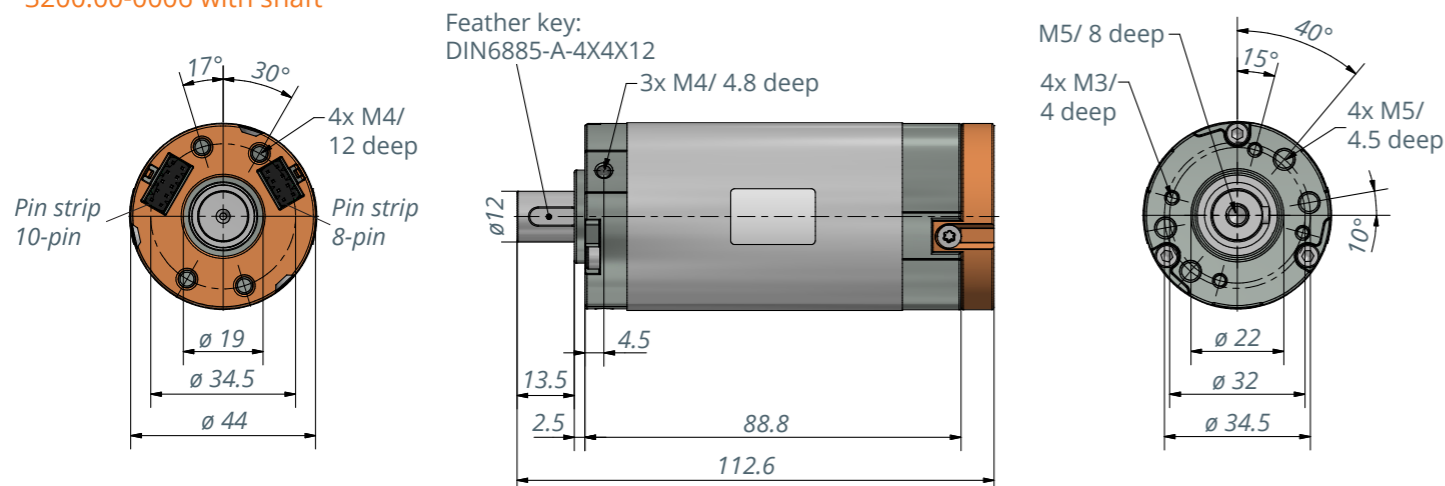

t-Rex 3200 I-44-89 L41 S2 DH	3200.00-0005 / 3200.00-0006		
Rated voltage	24 VDC	36 VDC	48 VDC
Rated current	1.7A	1.8 A	1.7 A
Rated torque	0.5 Nm	0.5 Nm	0.5 Nm
Rated speed	600 rpm	960 rpm	1347 rpm
Shaft power (output)	31 W	50 W	70 W
Max. efficiency	83 %	83 %	83 %
Idle speed	812 rpm	1221 rpm	1653 rpm
No-load current	0.3 A	0.2 A	0.2 A
Stall torque	1.8 Nm	2.3 Nm	2.9 Nm
Starting current at idle speed	6.6 A	8.7 A	11.2 A
Torque constant	0.279 Nm/A	0.264 Nm/A	0.261 Nm/A
Speed constant	34 rpm/V	34 rpm/V	34 rpm/V

Motor parameters

Terminal resistance (phase to phase)	2.6 Ohm
Terminal inductance (phase to phase)	1.6 mH
Rotor inertia	26.5 kg* mm ²
Number of poles	14
Interconnection of the motor	Star
Number of coils per phase	2
Interconnection of coils	2 Series
Direction of rotation	bidirectional

Note: Max. ambient temperature = 40 °C, controller-specific
At the nominal point (TU = 20°C), controller-specific

Motor cable approx. 1.5 m

Item number: 3200.53-05

Motor characteristics at 24 V

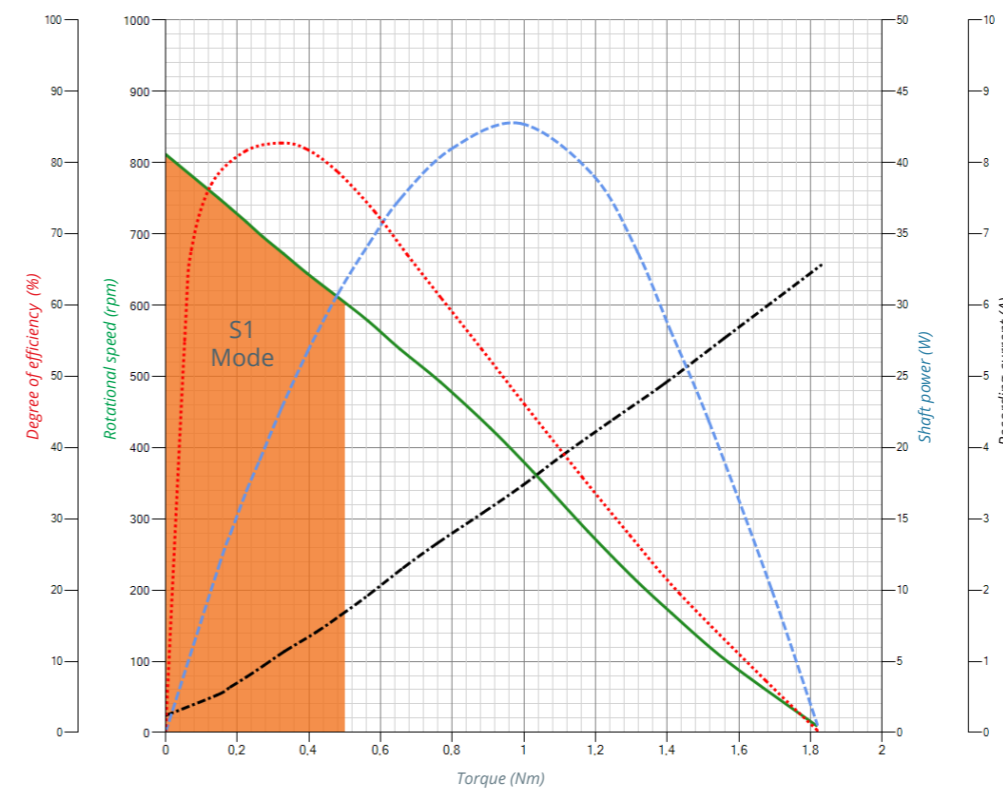

Motor phases

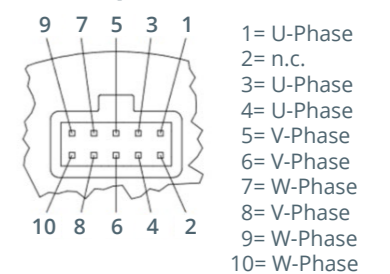

n.c.= please do not connect
RM 2.54 / 10 PIN
W+P 3491-10

Hall-sensors

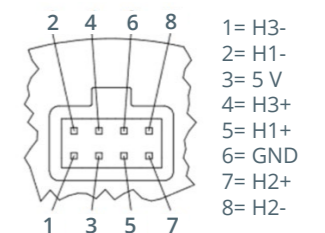

Socket strip RM 2.54 / 8 PIN
W+P 3491-08

Digital Hall-Sensors

Supply of sensors: Voltage range: 4.5 to 5.5 V DC, Optional: voltage regulator for 5 V, Input current: < 70 mA

Output signals of sensors: Differential output, (RS422 standard, datasheet AM26 C31-TI)

Typical voltage range: 0.2/ 3.4 V @ 20 mA / Output current: max. 20 mA

Signal structure: The Hall sensors have a 120° phase shift to each other. Due to the 14-pole design the

Signal frequency: Is seven times higher than the speed.